



Universal Air Suspension

463 W. Highland Ave

San Bernardino, CA 92405

800-864-2470

WWW.UniversalAirSuspension.com

Basic Assembly Manual for Installing The Universal "AEROSTRUT" Air Bag onto the Mc Pherson type strut

**Measure pressure tube on strut to make sure
diameter is 2.1 or under**

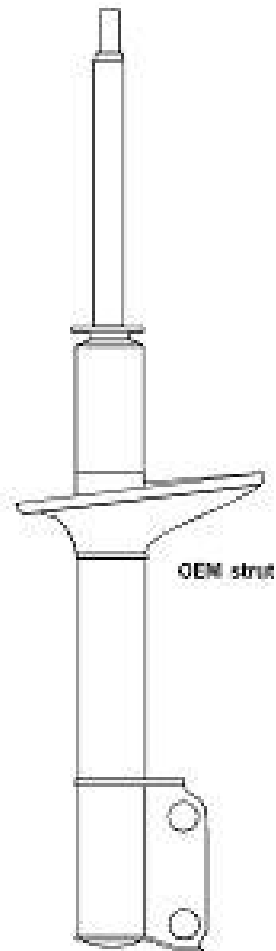
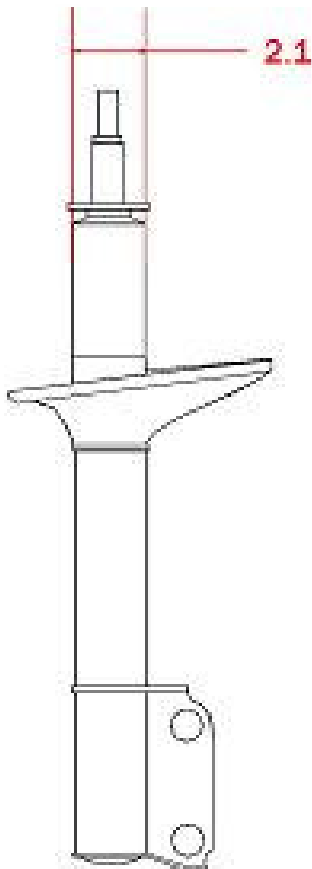



Universal Air Suspension

463 W. Highland Ave
San Bernardino, CA 92405
800-864-2470
WWW.UniversalAirSuspension.com

**make sure you have
3.5" clearance between
inner housing wall and
strut top mount point**

**it is important to check the
clearance measurement
so that the aerostrut will
not rub the inner housing wall**

top view

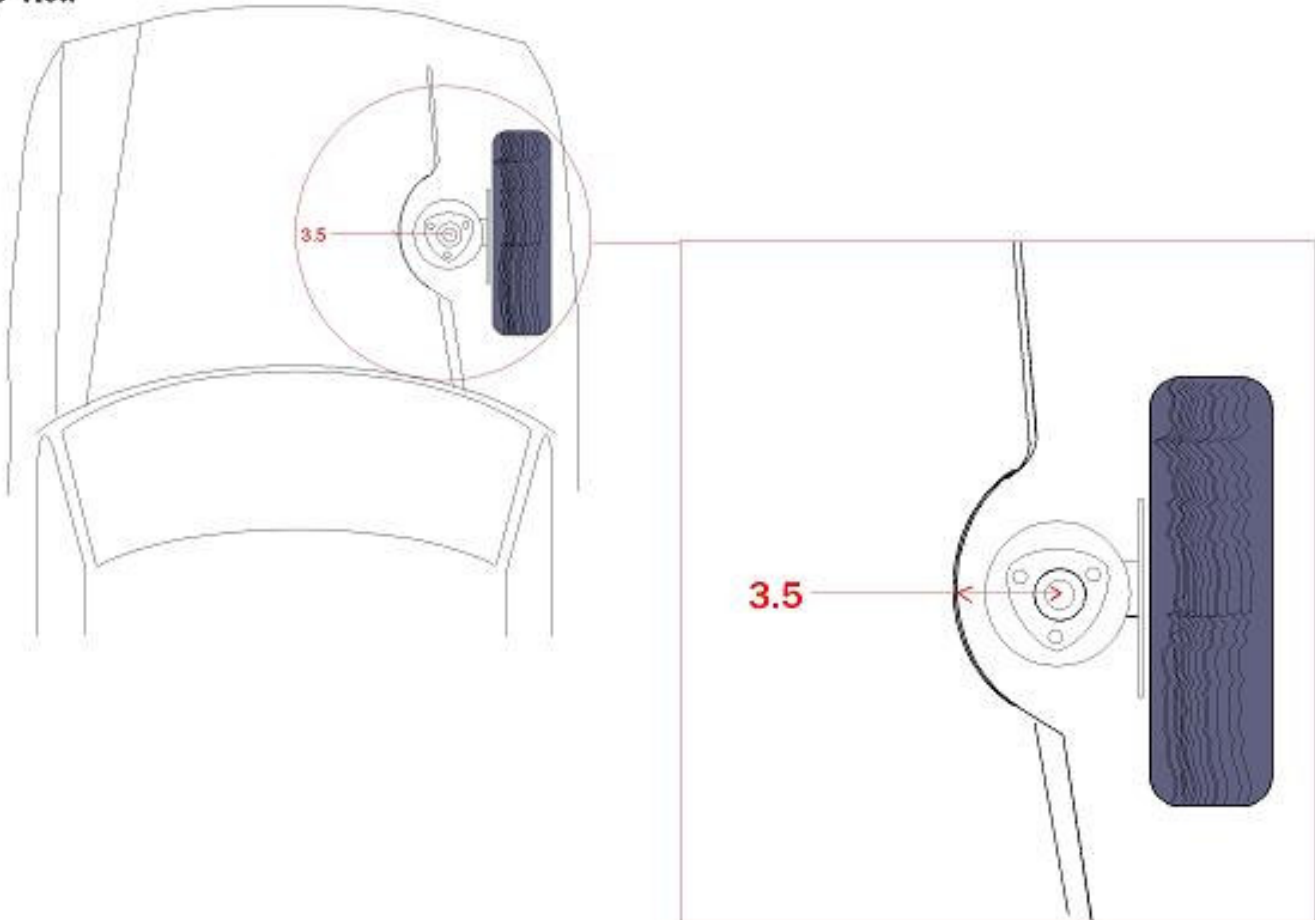



Universal Air Suspension

463 W. Highland Ave

San Bernardino, CA 92405

800-864-2470

WWW.UniversalAirSuspension.com

WARNING

**NEVER WELD ON
ANY PART OF THE
PRESSURE TUBE**

**Grind down collar ring
if needed**

**so that aerostrut can
fit over freely or on various
strut designs some collar cap
rings can be completely
removed by prying or popping off**

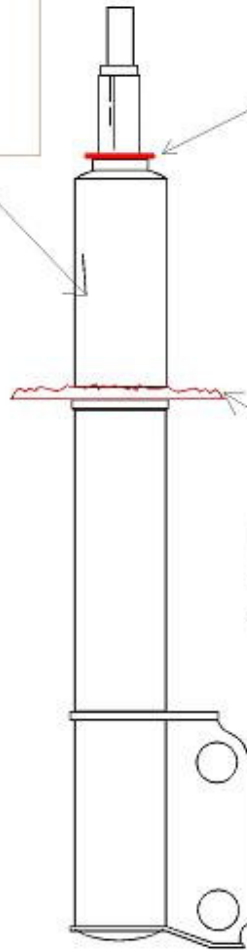

**because of coil setting angle
some strut saddle assemblies
will need to be modified or altered**

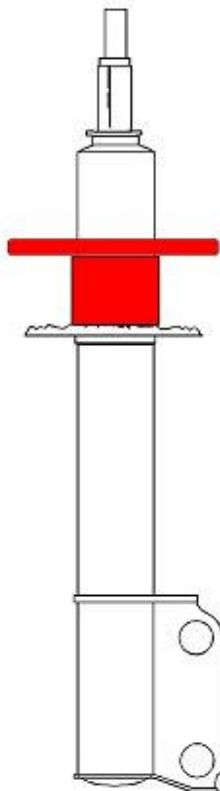

**Note: most strut assemblies
will require a perch section
or (doughnut) so that the
air bag will rest straight
and level**

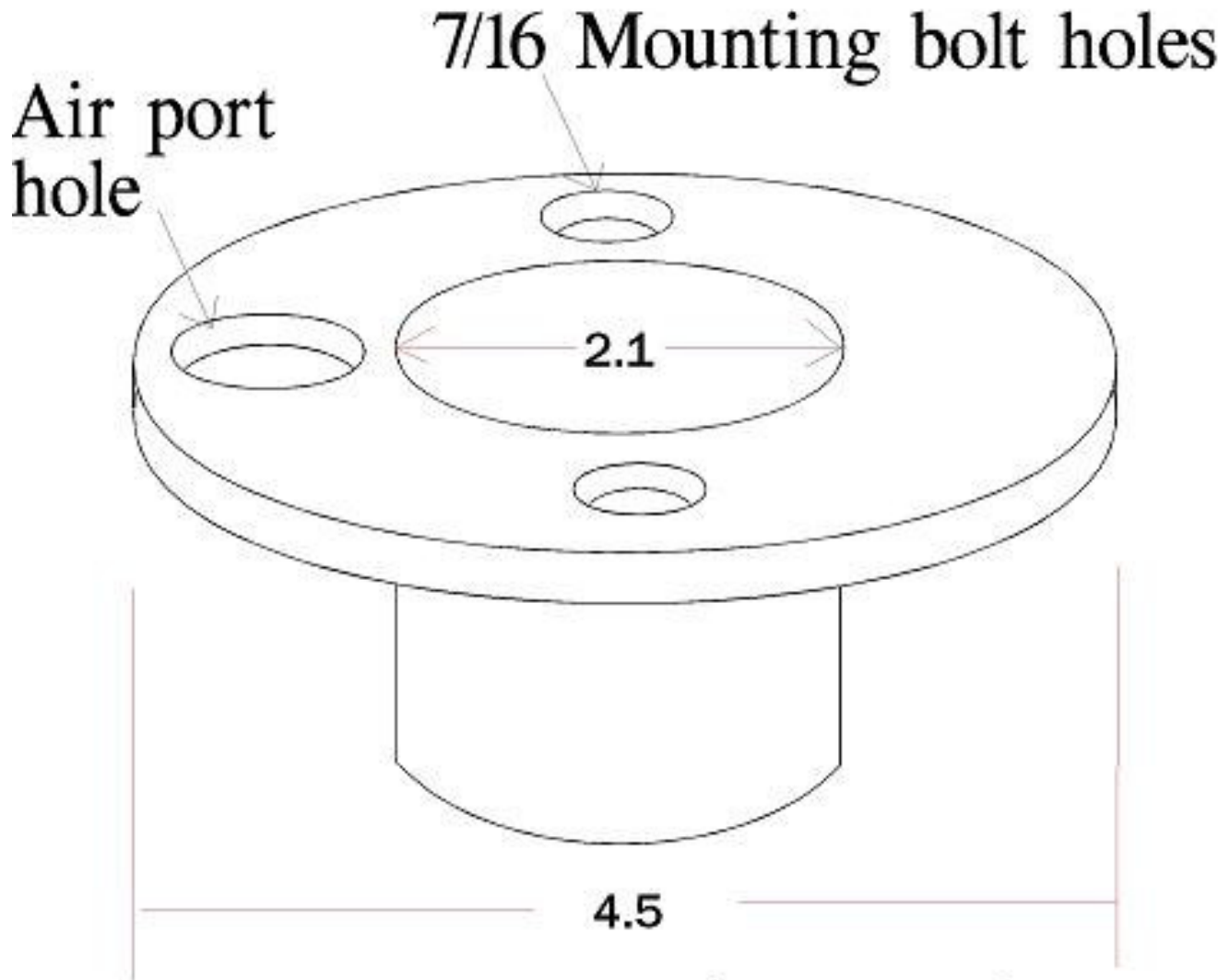

Bottom Perch (doughnut)

Installer must make a perch (doughnut style cup) out of metal, designed from this sample drawing specs.

Once the perch (doughnut) is made, it should slip over the pressure tube of the strut and be placed on top of the altered/modified saddle



Universal Air Suspension

463 W. Highland Ave
San Bernardino, CA 92405
800-864-2470
WWW.UniversalAirSuspension.com

front view

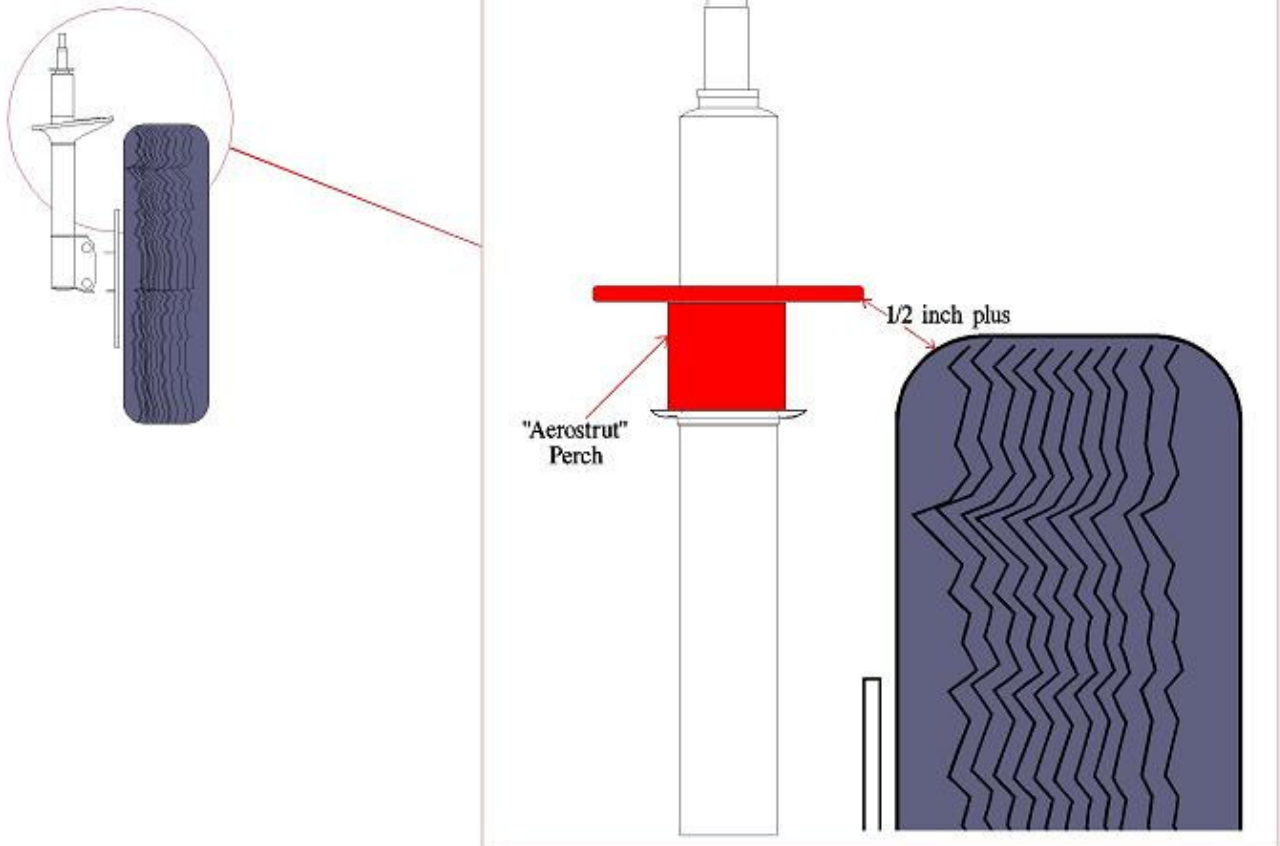

When perch (doughnut) is placed upon altered or modified saddle make sure purch flat plate setting allows "Aerostrut" air bag to rest at least 1/2" CLEARANCE just over automobile tire.

Universal Air Suspension

463 W. Highland Ave
San Bernardino, CA 92405
800-864-2470
WWW.UniversalAirSuspension.com

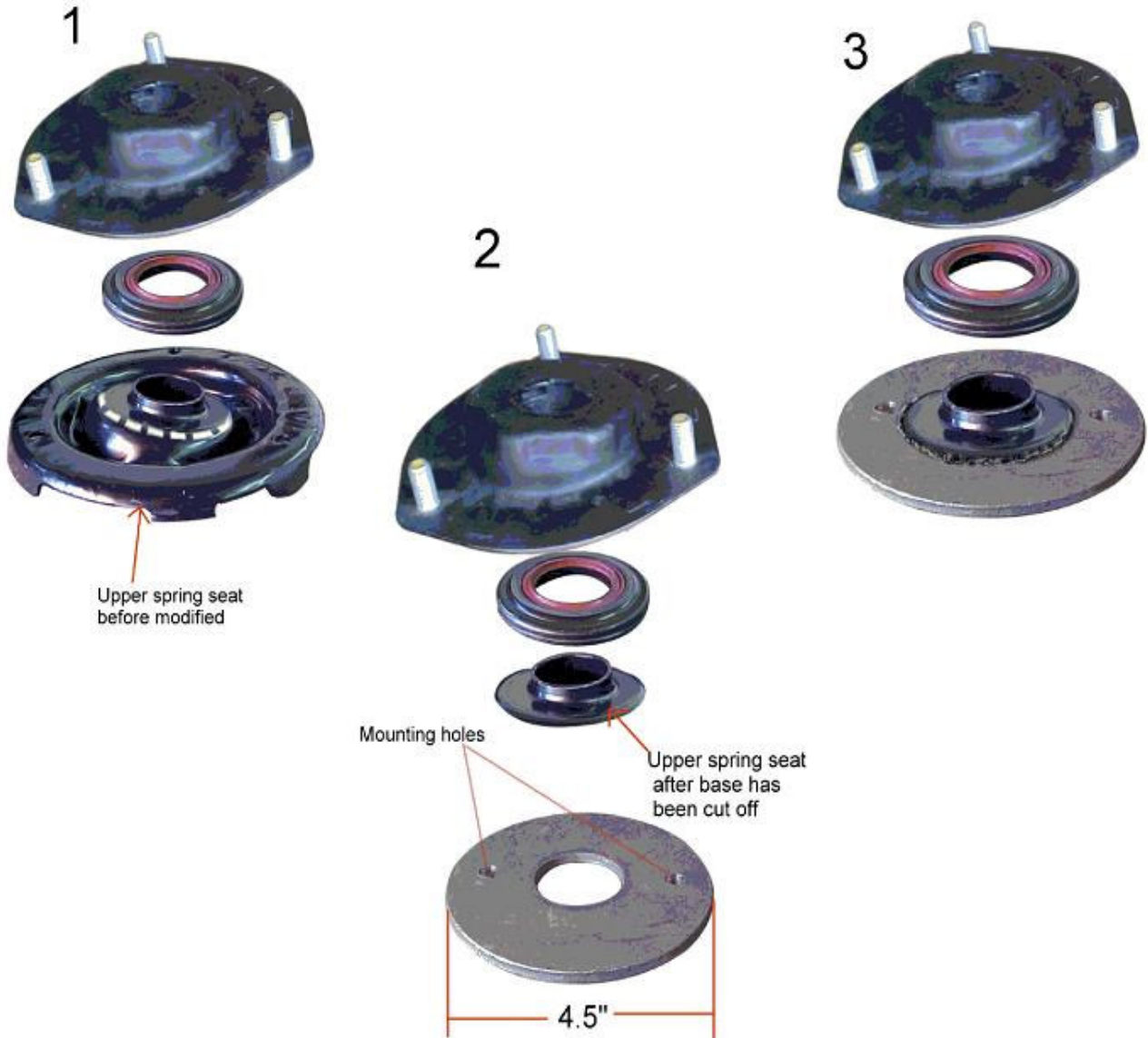

in most strut installations you can use the top dome part of the upper spring seat
Remove the bottom base section at best possible flat (level) area only, by cutting it away
Take a flat doughnut shape metal ring (drill air bag mount holes) weld both pieces together.

Universal Air Suspension Co. offers to our Customers / Installers an In-House assembly (parts&labor) of the "AEROSTRUT" on your Mc Pherson Type Strut

For Assistance or Tech Advice of our Products Visit or Contact us on our website www.universalairsuspension.com

Using NEW Upper Bearing

Not all cars have the same mount but this is an example on how it should look

